

NON-DISPOSAL *ka* IN TAIWAN SOUTHERN MIN*

Huei-Ling Lin
National Chung Cheng University

ABSTRACT

In addition to denoting disposal, *ka* in Taiwan Southern Min has other functions such as introducing goal, source, benefactive, and adversative. Like the disposal *ka*-construction, the *ka* NP in goal/source *ka* constructions is semantically related to the postverbal object. Compared with the disposal *ka*-construction, goal/source *ka*-constructions sometimes require one more postverbal argument. As for benefactive/adversative *ka*-constructions, they differ from the other *ka*-constructions in that the benefactive/adversative argument is often optional. This paper discusses the non-disposal *ka* constructions, and it argues that Lin's (2010) account of the disposal *ka*-construction can be applied to account for goal/source *ka*-constructions. The benefactive *ka*-construction and the adversative *ka*-construction are semantically related, and they also have the same structure. To sum up, among the four types of non-disposal *ka* construction, two of them (goal and source) are argued to have the same structure as that for a disposal *ka*-construction, and the benefactive/adversative *ka*-constructions have their own distinctive structure.

Key words: Taiwan Southern Min, *ka*-construction, patient, goal, source, benefactive, adversative

* Research for this paper was supported by a grant from the National Science Council (NSC 101-2410-H-194-112-). The author would like to thank the anonymous reviewers for their valuable comments and takes sole responsibility for any possible errors.

1. INTRODUCTION

Similar to *ba* in Mandarin Chinese, *ka* in Taiwan Southern Min (TSM)¹ can introduce the patient theta role as in (1). The other theta roles *ka* can introduce are classified into three types by Teng (1982): goal as in (2), source as in (3), and benefactive as in (4). In Tsao (2003), benefactive is taken to include adversative as well as in (5).

- (1) a. 伊 ka 我拍一下。
 i ka gua phah cit e.² (patient)
 he KA I hit one CL³
 'He hit me once.'
 b. *伊拍一下。
 *i phah cit e.
 he hit one CL
- (2) a. 伊 ka 我問一個問題。
 i ka gua mng cit e bunte. (goal)
 he KA I ask one CL question.
 'He asked me a question.'
 b. ?伊問一個問題。
 ?i mng cit e bunte.
 he ask one CL question.
- (3) a. 伊欲 ka 你罰錢哦?
 i beh ka li huat cinn o? (source)
 he want KA you fine money PRT
 'He would like to fine you?'

¹ Taiwan Southern Min (TSM) discussed in this paper refers to the Southern Min spoken by more than 80% of the people in Taiwan (Cheng 1985).

² The romanization used in this paper for Taiwan Southern Min examples is according to the TLPA (Taiwan Language Phonetic Alphabet), which was promulgated by the Ministry of Education in Taiwan in 1998.

³ Abbreviations used in this paper are listed below:

ASP: aspect, ASSOC: associate marker; CL: classifier, PASS: passive, PRT: particle.

airiti

Non-disposal Ka

b. ?伊欲罰錢哦?
?i beh huat cinn o?
he want fine money PRT

- (4) 伊咧 (ka 弟弟) 洗身軀。
i tih (ka titi) ce sinkhu. (benefactive)
he at KA brother wash body
'He is washing the brother's body.'
- (5) 伊 (ka 我) 搵破杯仔。
i (ka gua) kong-phua pue-a. (adversative)
he KA I hit-break cup
'He broke my cup.'

The *ka* NP is peculiar in at least two aspects: optionality and (superficial) displacement. First, among the five types of *ka*-construction, Tsao (2003) takes patient, goal, and source to be an obligatory argument as shown in (1-3), while benefactive/adversative is optional as in (4-5).

Second, the preverbal *ka* NP which carries the theta role of patient, goal, or source can often take the postverbal position as well, as shown in (6-8).

- (6) 伊拍我一下。
i phah gua cit e. (patient) (cf. (1))
he hit I one CL
He hit me once.'
- (7) 伊問我一個問題。
i mng gua cit e bunte. (goal) (cf. (2))
he ask I one CL question.
'He asked me a question.'
- (8) 伊欲罰你錢哦?
i beh huat li cinn o? (source) (cf. (3))
he want fine you money PRT
'He would like to fine you?'

The displacement of the benefactive or adversative *ka* NP in the postverbal position, however, is not acceptable as in (9) and (10).⁴

- (9) *伊咧洗弟弟身軀。
 *i tih ce titi sinkhu. (benefactive) (cf. (4))
 he at wash brother body
 ‘He is washing the brother’s body.’

- (10) *伊損破我杯仔。
 *i kong-phua gua pue-a. (adversative) (cf. (5))
 he hit-break I cup
 ‘He broke my cup.’

Regarding the discussion on *ka*, the disposal *ka*-construction, that is, the *ka*-construction introducing the patient theta role as in (1), has drawn much attention, and various proposals are available, including Tsao’s (2003) raising approach, Yang’s (2006) NOP (null operator) approach, and Lin’s (2010) control approach. This paper aims to adopt Lin’s control approach on the disposal *ka*-construction to explain the derivation and properties of the non-disposal *ka*-constructions introducing goal and source, and Lin’s (2012) proposal on adversatives is applied to benefactives. This paper is structured as follows. Section 1 introduces the properties of *ka*-construction. Section 2 reviews literature

⁴ In both (9) and (10), if the associative marker *e* is inserted between the benefactive/adversative and the patient as in (i) and (ii), the sentences are then grammatical. However, it should be noted that in (i) and (ii) only one NP follows the verb, *titi e sinkhu* ‘brother’s body’ in (i) and *gua e pue-a* ‘my cup’ in (ii).

- (i) 伊咧洗弟弟 e 身軀。
 i tih ce titi e sinkhu. (benefactive)(cf. (9))
 he at wash brother ASSOC body
 ‘He is washing the brother’s body.’
- (ii) 伊損破我 e 杯仔。
 i kong-phua gua e pue-a. (adversative) (cf. (10))
 he hit-break I ASSOC cup
 ‘He broke my cup.’

on *ka*-construction, and Section 3 presents the proposed analyses on non-disposal *ka*-constructions. Section 4 concludes this paper.

2. LITERATURE REVIEW

Regarding the semantic relation between the *ka* NP and the postverbal object, Hung (1995) and Tsao (2003) argue that the *ka* NP is base-generated as the object of the main verb and it is raised to the preverbal position and assigned Case by the preposition *ka*. As pointed out in Yang (2006), one of the problems with this raising approach is that the raising of the *ka* NP is not motivated as it already receives Case from the main verb.

In Yang's (2006) null operator approach, (11) is proposed to be the structure of *ka*-construction. In (11) the *ka* NP, *Abing*, is base-generated in the preverbal position. As for the object of the verb *phah* 'hit', it is occupied by a null operator, which moves up to adjoin to VP3 and is coindexed with the *ka* NP, *Abing*.

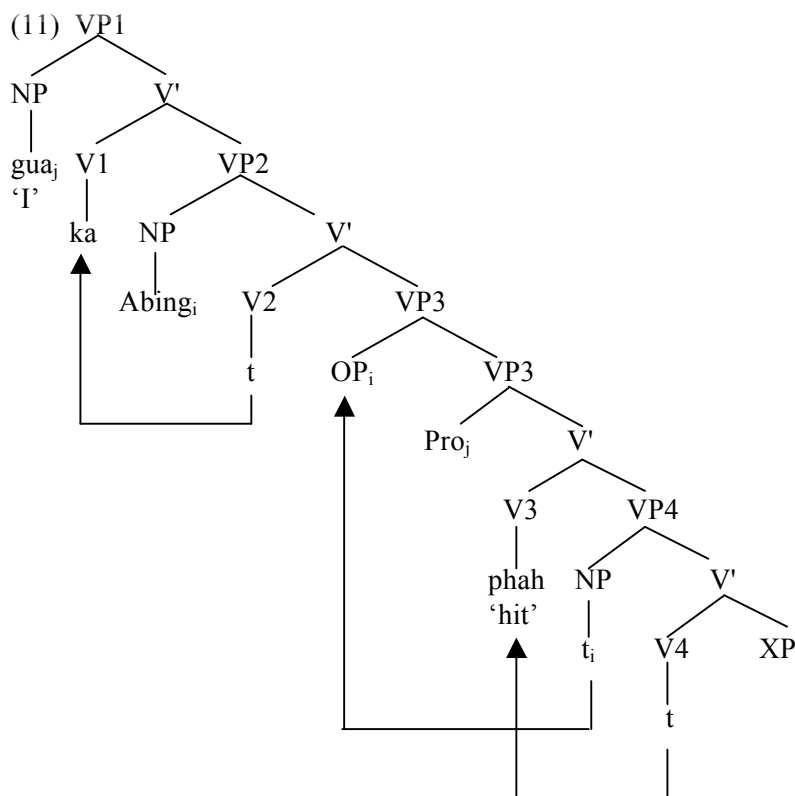

Yang's NOP analysis nicely captures the semantic relation between the *ka* NP and the object of the lower verb through null operator movement and coindexation. However, as pointed out in Lin (2010), this NOP analysis is still not without problems. First of all, the subject of the lower VP, i.e., *Pro*,⁵ is presented to be coindexed with the main subject, that is, *gua* 'I' in this case; however, this coindexation is not supported by any argument. Furthermore, control of *Pro* by the more distant NP *gua* is not consistent with the Generalized Control Rule, which states that an empty pronominal is controlled in its control domain (Huang 1989).⁶

⁵ The idea of *Pro* is due to Huang (1989).

⁶ The author would like to thank one of the reviewers for pointing this out.

Another problem with this NOP analysis is its accountability with *ciong* constructions such as (13) and (14). *Ciong* is another disposal marker in TSM, and the difference between *ciong* and *ka* is that those sentences containing *ciong* tend to occur in written discourse (Chappell 2000). *Ciong* may occur alone as in (13) or co-occur with *ka* as in (14).⁷ In a *ciong...ka* construction, a third person pronoun *i* may occur after *ka* as in (15).⁸ To put it another way, *i* is optional when it occurs after *ka* as in (14). In the structure under the NOP analysis, i.e., (11), the only possible position for *i* is the Pro position. Placing the third person pronoun *i* in the Pro position will result in the illogical meaning that he affected the shoes in the event in which they wore themselves threadbare.

(12) 伊 ka 鞋子穿破去矣。

i ka e-a ching-phuakhi a.
he KA shoes wear-threadbare PRT
'He wore his shoes threadbare.'

(13) 伊將鞋仔穿破去矣。

i ciong e-a ching-phuakhi a. (cf. (12))
he CIONG shoes wear-threadbare PRT
'He wore his shoes threadbare.'

⁷ One reviewer points out that (13) and (14) may differ in meaning. The minute meaning difference may be that when two disposal markers are used as in (14), the disposal meaning is stronger. That is, (13) simply describes the event, while (14) puts emphasis on what happens to the shoes.

⁸ The third person *i* can also be omitted when it occurs after the passive marker *hoo* as in (i).

(i) 我予 (伊) 拍著。
gua hoo (i) pah-tioh.
I PASS he hit-arrive
'I was hit by him.'

airiti

Huei-Ling Lin

(14) 伊將鞋仔 ka 穿破去矣。
i ciong e-a ka ching-phuakhi a.
he CIONG shoes KA wear-threadbare PRT
'He wore his shoes threadbare.'

(15) 伊將鞋仔 ka 伊穿破去矣。
i ciong e-a ka i ching-phuakhi a.
he CIONG shoes KA it wear-threadbare PRT
'He wore his shoes threadbare.'

Lin (2010) proposes (16) to be the structure of the disposal *ka*-construction in (12), and (16) is based on the structure proposed by Huang (1999) for short passives such as (17). The structure for a short passive such as (18) denotes the meaning that a person/object is affected in a certain event. The disposal construction, on the other hand, denotes the meaning that someone affects a person/object in the way that person/object is affected in a certain event. The short passive and the disposal construction differ in the presence of the agent; therefore, (18) is modified into (16) to accommodate the presence of the agent in a disposal construction. In (16), V1 and V2 are respectively occupied by the two verbs of the disposal construction, *ka* and *ching-phuakhi* 'wear-threadbare';⁹ *ka* as a light verb denotes the meaning of 'affect' (Li 2006; Lin 2001; Yang 2006) and subcategorizes for an NP object, NP2 in (16), and a VP which describes what the affected object undergoes,

⁹ Resultative compounds such as *ching-phuakhi* 'wear-threadbare' are argued to be derived from a structure that can be simplified as [_{VP} NP [_V V [_{VP} NP [_V V]]]] through V-to-V incorporation in syntax by Lin (2007). Lin (2010), however, does not show the detailed internal structure for the resultative compound *ching-phuakhi* as in (16). As the internal structure of the compound is not the focus of the discussion here and it does not affect the analysis, the detailed structure of the compound is not illustrated in this paper to simplify discussion. It should be noted that both a compound verb such as *ching-phuakhi* and a simple verb such as *phah* 'hit' as in (i) fits into (16) well.

(i) 伊 ka 我拍。
i ka gua phah.
he KA I hit
'He hit me.'

airiti

Non-disposal Ka

that is VP2 in (16). *Ka* has to move up from V1 to *v* to assign Case to *e-a* 'shoes' in NP2. VP2 in (16) involves a passivized verb, which does not assign Case to its object, NP4. As VP2 in (16) involves a passivized verb, thus only a transitive verb is allowed. As demonstrated in (19) an intransitive verb such as *thiau* 'jump' is not tolerated.

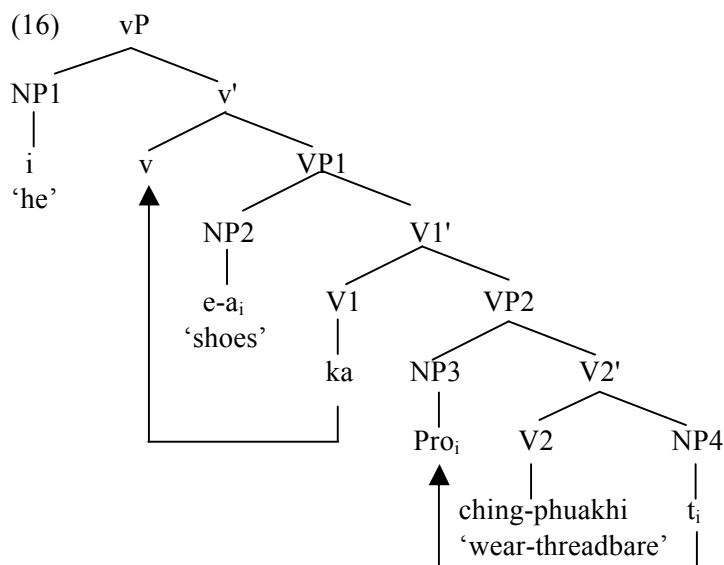

- (17) 老王被打了。
 Laowang bei da le.
 Laowang PASS hit ASP
 'Laowang was hit.'

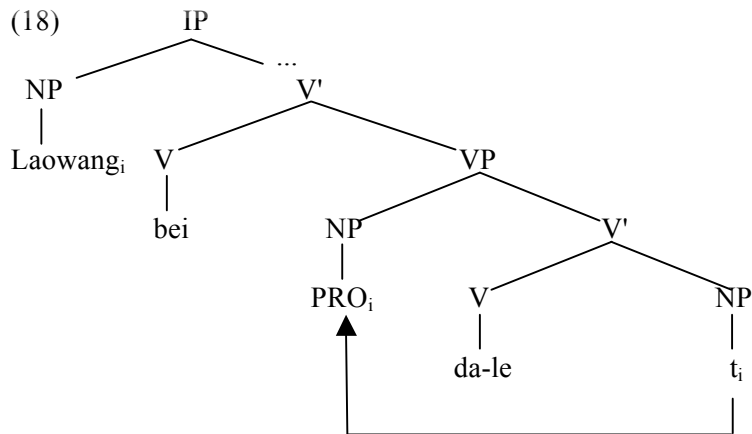

- (19) *我 ka 伊跳。
 *gua ka i thiau.
 I KA he jump
 intended meaning: ‘I affected him in the event in which I jumped.’

That VP2 in (16) involves a passivized verb is further proved by (20) which involves the active usage of the verb taking the object in the postverbal position.

- (20) 伊穿破鞋仔矣。
 i ching-phua e-a a.
 he wear-threadbare shoes PRT
 ‘He wore his shoes threadbare.’

In (16) Pro has to undergo A-movement from the object of *ching-phuakhi* ‘wear-threadbare’ to the VP-internal subject position since it is in a case-less position;¹⁰ Pro is then controlled by the closest NP c-commanding it, that is *e-a* ‘shoes’ (Principle of Minimal Distance (Chomsky 1980; Rosenbaum 1970)), and gets interpreted at this position.

¹⁰ *Ching-phuakhi* in VP2 in (16) is a passivized verb, and it cannot assign Case to its object. The object of *ching-phuakhi* is thus in a case-less position.

(16) thus expresses the meaning that he affected the shoes in the event in which the shoes were worn threadbare.

Lin's (2010) control approach can also explain the disposal construction involving the use of *ciong*. If V1 in (16) is occupied by *ciong*, not *ka*, after *ciong* is moved up to *v* to assign Case to *e-a*, (13) is derived.¹¹ Instead of moving up *ka*, if *ciong* is inserted in *v* and *ka* stays in-situ in V1, (14) is then derived as shown in (21).

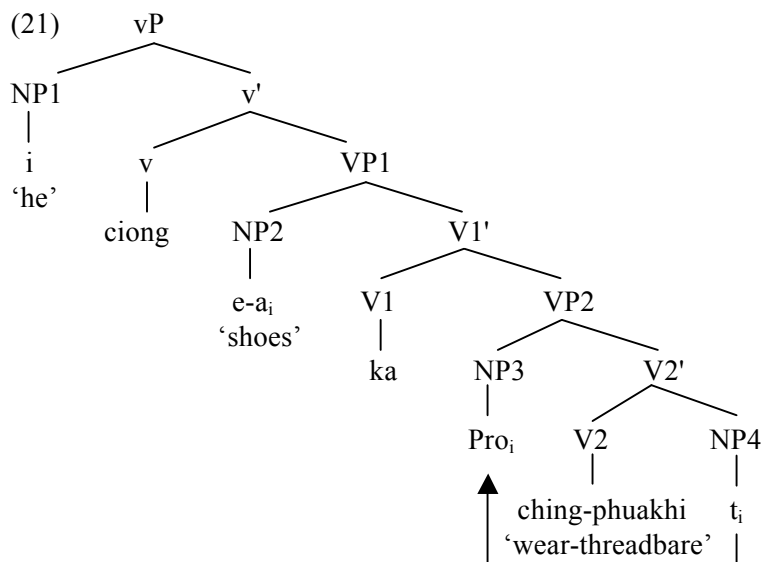

When *ka* remains in-situ and is available to assign Case to the Pro inside VP2, this Pro can be optionally filled with a pronoun that is coreferential with the NP object, as in (15), where *i* refers to *e-a* 'shoes.'¹² This offers more evidence proving that Pro moves up from the postverbal position to the preverbal position. Without the raising, the derivation of (15) cannot be accounted for. On the other hand, in cases where *ka* does not stay in-situ and Pro thus cannot get Case from it, *i* is not allowed as in (22-23), which have (24) as their structure. Lin (2010) has discussed disposal *ka*-construction in detail; however, the non-disposal

¹¹ (13) has the same structure as (16), except *ka* is replaced by *ciong*.

¹² (15) has the same structure as (21), except Pro is filled by *i*.

ka-constructions as in (2-5) are not under discussion in Lin (2010).

- (22) *伊 ka 鞋仔伊穿破去矣。
 *i ka e-a i ching-phuakhi a. (cf. (12))
 he KA shoes he wear-threadbare PRT
 'He wore his shoes threadbare.'

- (23) *伊將鞋仔伊穿破去矣。
 *i ciong e-a i ching-phuakhi a. (cf. (13))
 he CIONG shoes he wear-threadbare PRT
 'He wore his shoes threadbare.'

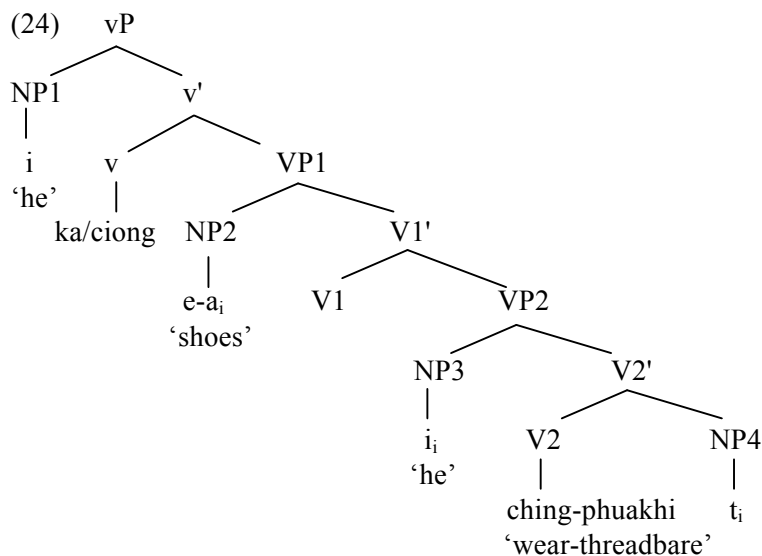

Benefactive and adversative arguments are often taken as optional. Tsao (2003) thus suggests that different from patient, goal, and source, benefactive and adversative arguments are base-generated in the preverbal position. Yang (2006) proposes only one structure as in (11) for *ka*-construction no matter what theta role the *ka* NP takes. The theta role that the *ka* NP takes is determined by the secondary predicate. However, the benefactive/adversative argument is optional and it cannot

take the postverbal position as shown in (9-10); therefore, the intended position for the object in OP in VP3 in (11) is not needed, and (11) cannot account for benefactive/adversative *ka*-construction.

Lin (2012) discusses adversative *ka*-construction such as (25) and proposes (26) to be its structure. Following Huang et al. (2009), Lin (2012) divides the complements taken by *ka* into two types: VP and IP. In a disposal *ka*-construction *ka* takes a VP as in (16), while in an adversative, *ka* is followed by an IP as in (26). In a disposal *ka*-construction, the *ka* NP is related to an argument within the VP subcategorized for by *ka*. To illustrate, in (16), the *ka* NP *e-a* ‘shoes’ is related to Pro inside VP2. That is, what is threadbare is the shoes in (16). The *ka* NP in an adversative *ka*-construction, however, is not related to any position inside the following phrase/sentence, which is complete in meaning. Moreover, the *ka* NP is affected by the event denoted by a sentence, not a verb phrase. To illustrate, in (26) the *ka* NP *gua* ‘I’ is affected by the event that he ran away. Huang et al. (2009) thus proposes that the adversative *ka* takes an IP complement. In a proposal that adopts a VP-internal subject hypothesis, one may equally argue that the adversative *ka* takes a VP which contains an internal subject as its complement. However, to clearly manifest the difference between the two types of complements taken by *ka*, this paper adopts the VP/IP distinction.

- (25) 伊竟然 *ka* 我走去。
 i kingjian ka gua cau-khi.
 he unexpectedly KA I run-away
 ‘He unexpectedly ran away on me.’

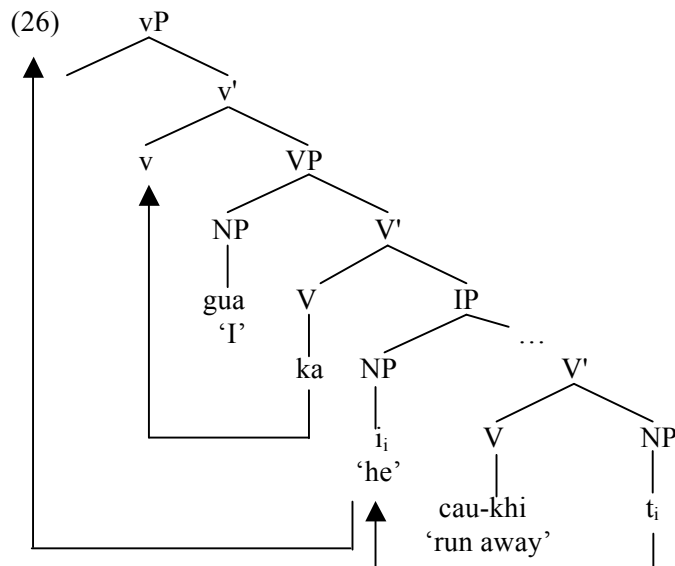

Tsai (2007) argues that in Mandarin adversatives such as (27), the main subject is moved up from the position of the embedded subject. Adversatives in TSM have the same semantic relation as those in Mandarin. Lin (2012) thus adopts Tsai's analysis to account for adversative *ka*-construction in TSM. That is, *cau-khi* 'run-away' in (26) is predicated of the embedded subject *i*, which is then moved up to the sentence-initial topic position.^{13, 14}

- (27) 他居然給我跑了。
 ta juran gei wo pao-le.
 he unexpectedly GEI I run-ASP
 'He unexpectedly ran away on me.'

¹³ The embedded subject has to move up because all clauses have subjects, following the Extended Projection Principle (Chomsky 1981).

¹⁴ Tsai (2007) has argued that the external argument occupies a topic position rather than a subject position. That is, the subject is further moved to the topic position.

Lin's (2012) proposal can capture the characteristics of adversatives; however, it does not further explain benefactives. This paper, therefore, aims to examine whether Lin's (2012) proposal for adversatives can be applied to explain benefactives.

3. THE PROPOSAL

The data collected for this study mainly come from story books. The data analyzed are sentences containing *ka* which introduces patient as in (28), goal as in (29), source as in (30), benefactive as in (31), and adversative as in (32).

- (28) 予蛇郎君 ka 你吞去? (蘆竹鄉閩南語故事集)
 hoo tsua long-kun ka li thun-khi? (patient) (Hu 1990)
 PASS snake man KA you swallow
 'You were swallowed by the snake man?'
- (29) 這個考生 ka 伊回答 (鳳山市閩南語故事集 (一))
 cit e khosing ka i huetap (goal) (Hu and Wang 1999)
 this CL examinee KA he answer
 'This examinee answered him.'
- (30) 海關的人 ka 伊沒收去 (趣味臺語選集)
 haikuan e lang ka i butsiu-khi (source) (Hsieh 1993)
 customs CL people KA he confiscate
 'People at the customs confiscated his stuff.'
- (31) 佢老母著 ka 人洗衫褲 (大安鄉閩南語故事集 (一))
 in lao-bu tiah ka lang se sann-khoo (benefactive)
 his mother then KA people wash clothes-pants (Hu and Wang 1998)
 'His mother washed clothes for other people.'

- (32) 欲來 ka 你抄家滅族 (朴子市閩南語故事集)
 beh lai KA li chiau ke biat cok (adversative)
 will come ka you kill family exterminate race (Huang 1999)
 ‘They will come to kill your whole family.’

Lin (2010) proposes (16) to be the structure of patient *ka*-construction. As discussed in the Literature Review, this proposal is more plausible than Tsao (2003) and Yang (2006). Therefore, this paper adopts Lin’s (2010) control proposal to explain goal and source *ka*-constructions. As for benefactive and adversative *ka*-constructions, these two constructions only differ in the effect caused by the event, which is either positive or negative. Therefore, it is possible that these two constructions share the same structure. On the basis of Lin’s (2012) account of adversative *ka*-construction, this study examines these two constructions.

3.1 Patient, Goal, and Source *Ka*-constructions

In the disposal *ka*-construction (16), the light verb *ka* denotes ‘affect’ and is subcategorized for an NP and a VP. (16) thus expresses the meaning that he affected the shoes in the event in which the shoes were worn threadbare. With *ka* denoting ‘affect’ and subcategorizing for an NP and a VP, this proposal can also be applied to goal and source *ka*-constructions. For instance, (29) has (33) as its structure, which expresses the meaning that this examinee affected him in the event in which he was answered.

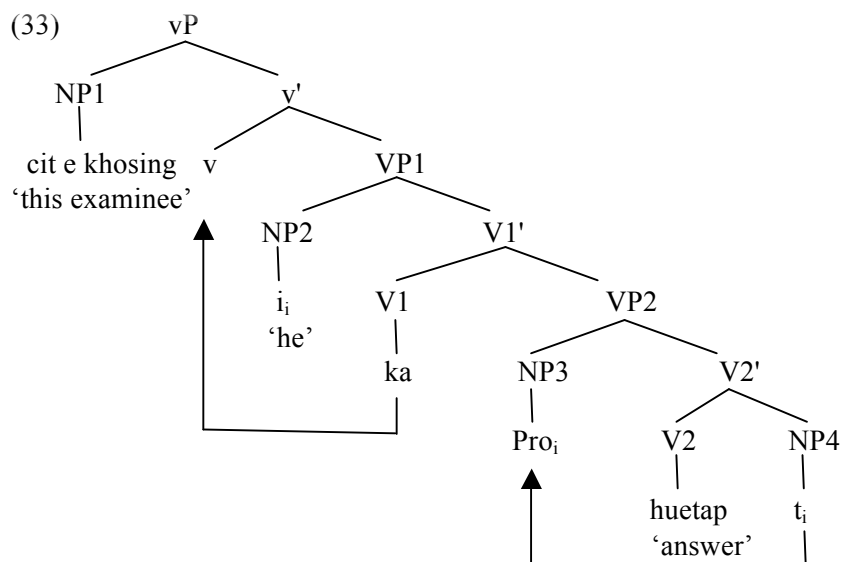

Goal/source introducing *ka*-constructions and patient introducing *ka*-construction bear the same structure. The theta-role the *ka* NP receives is determined by the main verb; for instance, *thun-khi* ‘swallow’ in (28) assigns the theta-role patient, while *huetap* ‘answer’ in (29) assigns goal.

However, goal/source *ka*-constructions and patient *ka*-construction differ in that the former may involve three-argument verbs such as *kong* ‘tell’ in (34a), while the latter often involves two-argument verbs such as *thun-khi* ‘swallow’ in (28).¹⁵ Yang (2011) takes goal and source

¹⁵ More examples involving three-argument goal/source *ka*-construction and two-argument patient *ka*-construction are provided below. As shown in (34a), (i), (ii), and (iii), verbs such as *kong* ‘tell’, *kau-tai* ‘tell’, *thong-po* ‘inform’, and *tho* ‘ask’ are three argument verbs. In addition to a theme argument, they assign one more argument, goal or source, which is introduced by *ka*. As for two-argument verbs as in (iv-v), they assign one argument, patient, which is introduced by *ka*.

- (i) 阿兄 ka 交代這件代誌
 a-hiann ka kau-tai cit kiann tai-ci. (goal)
 brother KA tell this CL matter
 ‘Brother told (him) this matter.’

airiti

Huei-Ling Lin

ka-constructions such as (34) to be dative construction. He believes that dative goal/source *ka*-constructions like (34) differ from other goal and source *ka*-constructions such as (2-3) in that the *ka* NP can be omitted in the dative construction as in (34b) and the *ka* NP cannot take the postverbal position as in (34c).

- (34) a. 伊 *ka* 我講一个故事。
i ka gua kong cit e koosu. (goal)
he KA I tell one CL story
'He told me a story.'
- b. 伊講一个故事。
i kong cit e koosu.
he tell one CL story
'He told a story.'
- c. *伊講我一个故事。
*i kong gua cit e koosu.
he tell I one CL story
'He told me a story.'

-
- (ii) 伊攞會 *ka* 通報消息
i long e ka thong-po siau-sit (goal)
he all will KA inform news
'He will inform (him) of the news.'
- (iii) 伊猶原 *ka* 討錢
i iu-guan ka tho cinn (source)
he still KA ask money
'He still asked money (from him).'
- (iv) *ka* 冊買轉來
ka cheh be tng-lai (patient)
KA book buy back
'buy books'
- (v) *ka* 擯
ka kong-lue (patient)
KA hit
'hit (him)'

Under the current proposal, example (34a), the so-called dative construction by Yang (2011), is argued to have (35) as its structure, which differs from (33) in the VP2-internal structure and which expresses the meaning that he affected me in the event in which I was told a story. Larsonian VP-shell analysis is adopted here for three-argument verbs (Larson 1988), and inside the VP subcategorized for by *ka*, i.e. VP2, two VP-shells are adopted, one headed by V2 and the other by V3.¹⁶

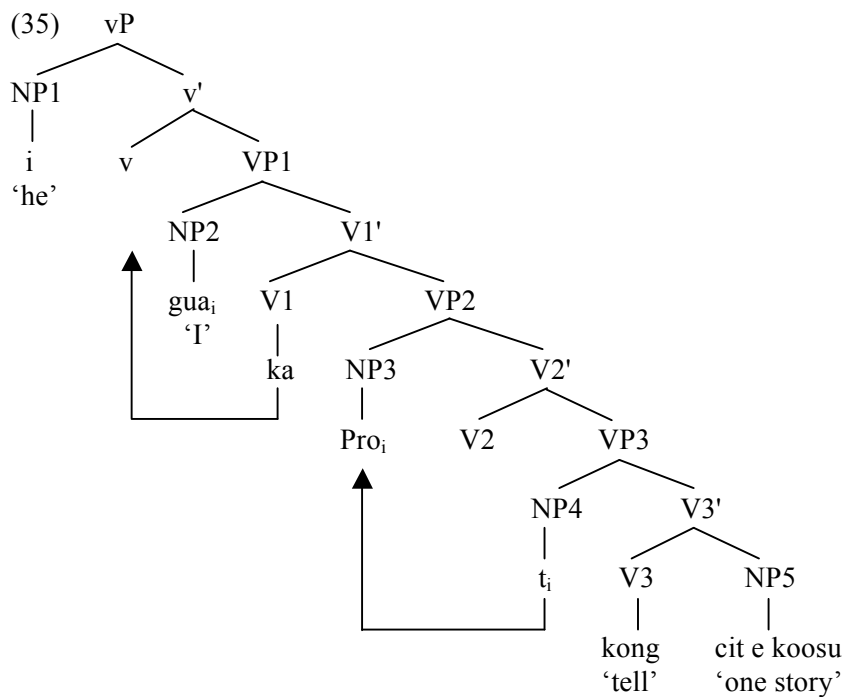

Whether to take an extra argument in goal/source *ka*-construction is determined by the verb, a two-argument verb or a three-argument verb.

¹⁶ Because inside VP2 the movement of Pro from NP4 to NP3 applies vacuously, it is not evident that V2 exists. However, if Larsonian VP-shell analysis is strictly followed, for a three-argument verb such as *kong* 'tell' two VP-shells should exist in VP2 headed by *kong*.

That is, this is a lexical matter. Therefore, there is no need to posit a totally different structure for three-argument goal/source *ka*-construction. The difference is well captured in the VP2-internal structure, where the verb may need one or two internal arguments.

Yang (2011) has mentioned that the *ka* NP in some goal and source *ka*-constructions can be omitted as in (34b). This omission can still be accounted for in this current proposal by not projecting the phrase headed by *ka* in (35) as shown in (36).

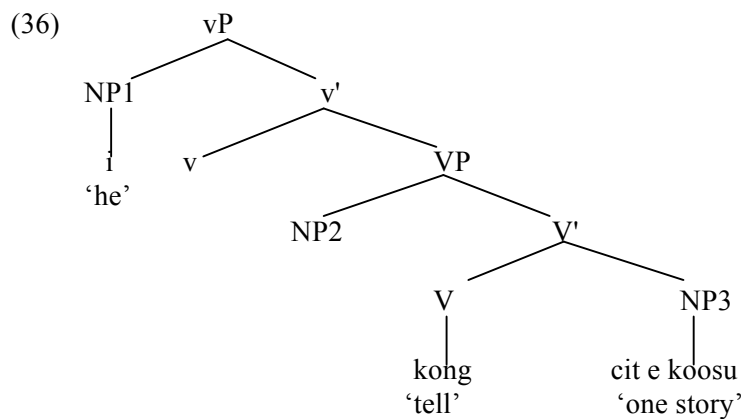

As a sentence without a *ka* NP, it is more than natural not to project the phrase headed by *ka*. Moreover, even though *ka* is subcategorized for a passivized VP in (35),¹⁷ now in (36) without *ka*, the VP in structure (36) is a regular active one. The omission of a *ka* NP certainly leads to meaning difference in that the goal argument is not specified in (34b), while in (34a) the goal argument is clearly specified to be the NP introduced by *ka*. It should be noted that even though the goal is not specified in (34b), it is still implied. That is, in (34b) there exists an unspecified goal, which takes the NP2 position in (36).

As mentioned in section 1, patient, goal, and source are often taken as obligatory arguments as shown in (1-3) (Tsao 2003). That is, the goal/source argument is obligatory for the verb in (2-3). Even though for

¹⁷ That *ka* is subcategorized for a passivized VP is argued for in Section 2 where the structure for the disposal *ka*-construction, i.e. (16), is discussed.

some verbs, the goal/source argument may appear to be optional as shown in (34b), the goal/source is still implied. That is, the goal/source is still perceived to exist, though not specified. Also mentioned in section 1 is that the preverbal *ka* NP which carries the theta role of patient, goal, or source can often take the postverbal position as shown in (6-8). This property demonstrates that the preverbal *ka* NP in patient/goal/source *ka*-constructions is related to a position after the verb. Thus, it provides evidence that the patient, goal, and source argument is related to a position inside the verb phrase, i.e. Pro in VP2 in (16). However, this paper does not argue that the two sentences, the one with *ka* such as (2a) and the one without *ka* such as (7), are structurally related. A raising account that proposes that the *ka* NP is base-generated as the object of the main verb and then raised to the preverbal position and assigned Case by *ka* (Hung 1995; Tsao 2003) is already proven to be problematic in section 2. The reason why the two sentences are semantically similar is that they involve the same three-argument verb, *mng* ‘ask’.

As for whether a verb can take two postverbal objects or not, it is a verb specific matter; that is, it is a matter of whether the verb allows double object construction. For instance, *mng* ‘ask’ in (7) can take two postverbal objects, while *kong* ‘tell’ in (34c) cannot. With (36) as the structure for both (7) and (34c), NP2 can be filled when the verb is *mng*, but not when the verb is *kong*. This matter is not related to the formation of *ka*-construction.¹⁸ Not only that, whether a transitive verb can take a postverbal object is often not related to the formation of *ka*-construction. For instance, even though the *ka* NP in (37) is semantically related to the postverbal object, it cannot take the postverbal position as in (38) because in Chinese three syllable verbs often cannot take a postverbal object.

- (37) 伊 *ka* 衫洗清氣矣。
 i ka sann se ching-khi a.
 he KA clothes wash clean PRT
 ‘He washed the clothes clean.

¹⁸ This is not due to the meaning of the verb, either. To illustrate, even though *kong* ‘tell’ cannot take two postverbal objects, its English counterpart can as in *He told me a story*.

- (38) *伊洗清氣衫矣。
 *i se ching-khi sann a.
 he wash clean clothes PRT
 'He washed the clothes clean.'

3.2 Benefactive/adversative *Ka*-constructions

Benefactive and adversative *ka*-constructions only differ in the effect (positive or negative) denoted by the event. That is, the two *ka*-constructions are basically the same, and the effect caused by the event may be perceived as positive or negative depending on the meaning of the event. Therefore, it is likely that the two constructions have the same structure. Applying the structure for adversatives as in (26) to explain a benefactive *ka*-construction such as (31) seems to work. As shown in (39), *ka* denotes 'affect' and is subcategorized for an NP, the one affected, and an IP. In the IP *se sann-khoo* 'wash clothes' is predicated of the embedded subject *in lao-bu* 'his mother'; *in lao-bu* then moves up to the topic position, and the correct word order is derived.

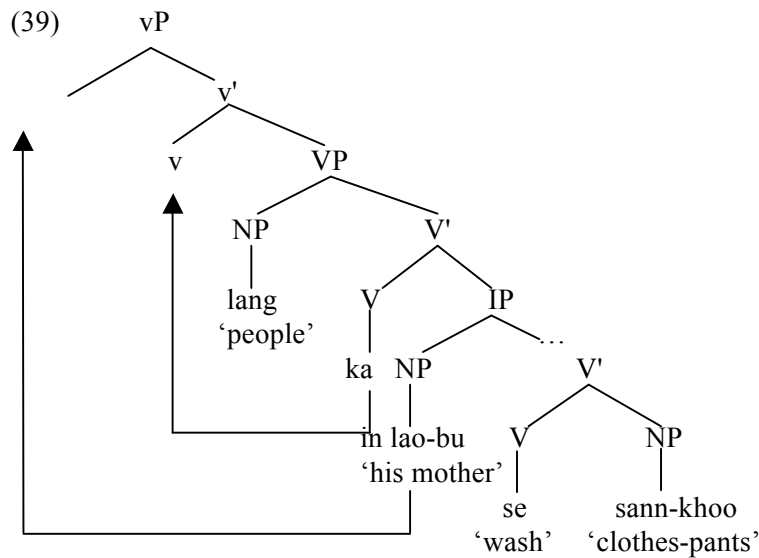

One of the features that distinguish patient/goal/source *ka*-constructions from benefactive/adversative *ka*-constructions is that the patient/goal/source argument is not optional as in (1-3), while the benefactive/adversative argument is optional as shown in (4-5). Take (40) as an example. When the benefactive *ka* NP is omitted, (40b) certainly has a meaning different from that of (40a); that is, the benefactee is not specified in (40b). However, unlike the omission of a goal/source as in (34b) where the unspecified goal is still implied, (40b) does not imply the existence of a benefactee. That is, (40b) is simply describing a clothes-washing activity. In comparison with the structure for (40a), i.e. (39), which can be applied to (40a) as well, the structure for (40b), as specified in (41), only involves the lower IP without the *ka* projection. That is why (40b) expresses the activity only.

- (40) a. 伊咧 ka 我 洗衫。
 i tih ka gua se sann.
 he at KA I wash clothes
 'He is washing clothes for me.'
- b. 伊咧 洗衫。
 i tih se sann.
 he at wash clothes
 'He is washing clothes.'

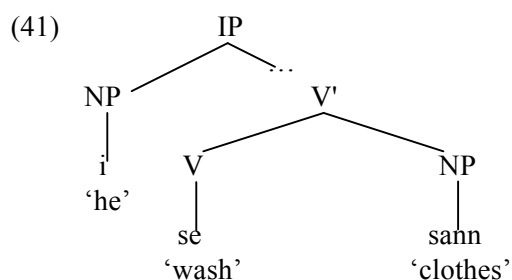

Another feature that distinguishes patient/goal/source *ka*-constructions from benefactive/adversative *ka*-constructions is that the patient/goal/source argument can often take the postverbal position

as well as in (6-8), while the benefactive/adversative argument cannot as in (9-10). Again this feature proves that the benefactive/adversative argument is not related to any position in the following phrase/sentence. As demonstrated in (39), there is no empty pronominal inside IP that is related to the benefactive *ka* NP.

4. CONCLUDING REMARKS

Among the five *ka*-constructions, this paper has argued that they all involve *ka* as a light verb denoting ‘affect’, and the specific theta-role carried by the affected *ka* NP is determined by the main verb. Patient, goal, and source introducing *ka*-constructions have similar structures. The extra argument of a three-argument verb in goal/source *ka*-constructions is projected in the VP-internal structure. As for benefactive and adversative *ka*-constructions, they only differ in the effect denoted by the event, positive or negative, and they are argued to have the same structure. The displacement of the *ka* NP, that is, the semantic relation between the *ka* NP and a postverbal position, is explained by the control relation between the *ka* NP and the Pro in VP-internal structure. In sum, this paper has proposed two different structures for the five *ka*-constructions in TSM. The five *ka*-constructions all involve the light verb *ka* which denotes ‘affect’, and the *ka* is subcategorized for an NP and a VP/IP.¹⁹

¹⁹ That a verb may have two different c-selections is not peculiar to *ka*. As shown in the following examples, the verb *know* is subcategorized for an NP or an IP.

- (i) I know the answer.
- (ii) I know that you know the answer.

REFERENCES

- Chappell, Hilary. 2000. Dialect grammar in two early modern Southern Min texts: A comparative study of dative *kî* 乞, comitative *câng* 共 and diminutive *-guà* 仔. *Journal of Chinese Linguistics* 28: 247-302.
- Cheng, Robert. L. 1985. A comparison of Taiwanese, Taiwan Mandarin, and Peking Mandarin. *Language* 61: 352-377.
- Chomsky, Noam. 1980. On binding. *Linguistic Inquiry* 11: 1-46.
- Chomsky, Noam. 1981. *Lectures on Government and Binding*. Dordrecht: Foris.
- Hsieh, Shu-Chuan. 1993. *Collection of Southern Min Fun Stories (Quwei Taiyu Xuanji)*. Taipei: Wang-wen Publisher.
- Hu, Wan-Chuan, and Chang-Hua Wang. 1999. *Feng-shan City Collection of Southern Min Stories (Feng-shan City Minnan Yu Gushi Ji)*. Gang-shan Township, Kaoshiung County: Kaoshiung County Cultural Center.
- Hu, Wan-Chuan, and Cheng-Hsiung Wang. 1998. *Da-an Township Collection of Southern Min Stories Volume I (Da-an Xiang Minnan Yu Gushi Ji (Yi))*. Feng-yuan City: Taichung County Cultural Center.
- Hu, Wan-Chuan. 1990. *Lu-chu Township Collection of Southern Min Stories (Lu-chu Xiang Minnan Yu Gushi Ji)*. Taoyuan City: Taoyuan County Cultural Center.
- Huang, C.-T. James, Y.-H. Audrey Li, and Yafei Li. 2009. *The Syntax of Chinese*. Cambridge: Cambridge University Press.
- Huang, C.-T. James. 1989. Pro-drop in Chinese: A generalized control theory. In *The Null Subject Parameter*, eds. by Osvaldo Jaeggli, and Kenneth J. Safir, pp.185-214. Dordrecht: Kluwer Academic Publishers.
- Huang, C.-T. James. 1999. Chinese passives in comparative perspective. *Tsing Hua Journal of Chinese Studies* 29: 423-509.
- Huang, Che-Yong. 1999. *Pu-zi City Collection of Southern Min Stories (Pu-zi City Minnan Yu Gushi Ji)*. Puzi City, Chiayi County: Chiayi County Cultural Center.
- Hung, Su-chen. 1995. *A Study of the Taiwanese Preposition KA and Its Corresponding Mandarin Prepositions*. Hsin-chu: National Tsing Hua University MA Thesis.
- Larson, Richard K. 1988. On the double object construction. *Linguistic Inquiry* 19: 335-391.
- Li, Y.-H. Audrey. 2006. Chinese ba. In *The Blackwell Companion to Syntax Vol. I*, eds. by M. Everaert, and H. van Riemsdijk, pp.374-468. Malden: Blackwell Publishing.
- Lin, Huei-Ling. 2007. Parallel morphology: Taiwanese verbal complexes. *Journal of Chinese Linguistics* 35: 335-371.
- Lin, Huei-Ling. 2010. The disposal marker *ka* in Taiwan Southern Min. In *Boundary Crossing: New Visions of Instruction and Research*, ed. by Jane S. Tsay, pp.19-44. Taipei: The Crane Publishing Company.
- Lin, Huei-Ling. 2012. A non-uniform analysis of *ka*⁷ Constructions in Taiwan Southern Min. *Language and Linguistics* 13: 743-766.
- Lin, T.-H. Jonah. 2001. *Light Verb Syntax and the Theory of Phrase Structure*. Irvine: University of California, Irvine dissertation.

- Rosenbaum, Peter S. 1970. A principle governing deletion in English sentential complementation. In *Readings in English Transformational Grammar*, eds. by Roderick A. Jacobs, and Peter S. Rosenbaum, pp.20-29. Waltham: Ginn and Company.
- Teng, Shou-hsin. 1982. Disposal structures in Amoy. *Bulletin of the Institute of History and Philosophy* 53: 331-352.
- Tsai, Wei-Tien Dylan. 2007. Four types of affective constructions in Chinese. Paper presented at The 5th Workshop on Formal Syntax and Semantics (FOSS-5) and The Taiwan Languages and Teaching Conference, April 21-22, 2007, National Kaohsiung University, Kaohsiung, Taiwan.
- Tsao, Feng-fu. 2003. On *ka* sentences in Taiwan Southern Min (Taiwan Minnan yu de ka ziju). In *Proceedings of the First International Conference on Chinese Dialect Grammar*, Haerbin, pp.114-136.
- Yang, Barry C.-Y. 2006. Syntactic structure of *ka*-construction in Taiwanese Southern Min. *USTWPL* 2: 141-171.
- Yang, Barry C.-Y. 2011. Revisiting the *ka*-construction in Taiwan Southern Min. Paper presented at The 12th Conference on Min Languages, November 5-6, 2011, Academia Sinica, Taipei.

[Received 17 October 2013; revised 12 February 2014; accepted 27 August 2014]

Huei-Ling Lin
Department of Foreign Languages & Literature
National Chung Cheng University
Chiayi, Taiwan 621, ROC
folhll@ccu.edu.tw

台灣閩南語中非表處置意的 *Ka*

林惠玲
國立中正大學

台灣閩南語的 *ka* 字除了引導受事者外，尚可引導標的、來源、受惠者、受害者論旨。受事者、標的、來源 *ka* 字句的 *ka* 名詞組與動後受詞語意相關。另外，與受事者 *ka* 字句相較之下，標的、來源 *ka* 字句通常除主詞外，動詞尚需二論元。而受惠者/受害者 *ka* 字句與其他 *ka* 字句不同處在於，受惠者/受害者論元常為非必要論元。本文討論的對象為非表處置意的 *ka* 字句。本文採用 Lin (2010) 就處置意 *ka* 字句所提出的分析法來解釋標的/來源 *ka* 字句的結構。另外，受惠與受害 *ka* 字句語意相關，並且有相同的結構。這四類非表處置意的 *ka* 字句中，兩類（標的、來源）跟表處置意 *ka* 字句有相同的結構，而受惠者/受害者 *ka* 字句則有其獨有的結構。

關鍵字：台灣閩南語、*ka* 字句、受事者、標的、來源、受惠者、受害者